

CALIBRE

1045

31 CHRO C 12 RA PC CALD CORR CORJ A24 STS PS C60 17 jewels

<p>∅ 31.00 mm</p>	
<p>Movement height</p>	<p>8.20 mm</p>
<p>Power-reserve Jewel number Frequency Angle of lift</p>	<p>45 h 17 28'800 A/h 53°</p>



MANIPULATION
of the chronograph pusher

Pusher "A" 1st push = start of hands C - D - E
 2nd push = stop of hands C - D - E
 Pusher "B" push = reset to zero of hands C - D - E
 when stopped.

of the winding crown

Position 1 (against the case) manual winding
Position 2 (middle) rapid correction of date by turning the winding crown in clockwise direction
 rapid correction of day by turning the winding crown in anti-clockwise direction
Position 3 (exterior) time setting
 stop of small-second

Automatic wrist-chronograph with 2 pushers in the usual position. Chronograph coupling by disc system. Hour, minute and second hammers self-coordinated. Sweep second hand. Central 60 minute recorder hand. 12-hour recorder hand. Synchronization of the 3 chronograph hands is ensured by a single wheel-train chain. Small second hand. 24-hour indicator. Stop-second device. Day-date indicators with rapid corrector. Automatic unidirectional winding of simple conception. Fine adjustment system with mobile stud-holder. Removal of barrel without disassembling of movement.

DISASSEMBLING

Parts in synthetic material : should be manipulated carefully and not held by the functional sections.

Op. No.	Order of operations	Part No.	Fixing device	Remarks
---------	---------------------	----------	---------------	---------

1.0. EXTERIOR

1.1.	Reset chronograph hands to zero			
1.2.	Open case			
1.3.	Winding stem	1106	Pressure lever	
1.4.	Uncase			
1.5.	Insert movement in movement holder			The movement holder with pushers for cal. 1040 may be used
1.6.	Refit winding stem		Pressure lever	
1.7.	Turn movement over			
1.8.	Sweep second hand			Extraction according to fig. 8
1.9.	Hour hand Minute hand Minute recorder hand			
1.10.	Hour recorder hand			
1.11.	24-hour hand			
1.12.	Small second hand			
1.13.	Dial		by pressure	For extraction : use levers in positions 4 h and 10 h
1.14.	Turn movement over			

2.0. AUTOMATIC MECHANISM

2.1.	Rotor gib	1451		
2.2.	Rotor	1026		
2.3.	Rotor pinion	1429		
2.4.	Impulse click	1412	1 screw 2694	Disassembling not necessary
2.5.	Automatic device bridge	1031	1 screw 2673	
2.6.	Reduction gear	1432		
2.7.	Stop click	1414		

Op. No.	Order of operations	Part. No.	Fixing device	Remarks
---------	---------------------	-----------	---------------	---------

3.0. MOTOR - WHEEL TRAIN - ESCAPEMENT - UPPER MECHANISM

3.1.	Let down mainspring	1208		By moving spring-click 1104 away from crown wheel 1101	
3.2.	Barrel axle	1204		Extraction as per fig. 19	
3.3.	Barrel drum - ratchet wheel	1202 1100		To separate the 2 parts see fig. 6	
3.4.	Balance cock	1030	1 screw 2583		
3.5.	Pallet cock	1005	2 screws 2583		
3.6.	Pallet fork	1316			
3.7.	Coupling lever spring	1731	1 screw 2583		
3.8.	3/4 plate bridge	1002	2 screws 2583		
3.9.	Driving gear for ratchet wheel	1437			
3.10.	Crown wheel cover	1168			
3.11.	Crown wheel	1101			
3.12.	Coupling lever and coupling gear	1724 1712			Cannot be extracted separately
3.13.	Intermediate wheel	1212			
3.14.	Escape wheel	1305			
3.15.	Fourth wheel	1243			
3.16.	Chronograph runner	1705		Move friction-spring 1735 away from chronograph runner 1705 without deforming it	
3.17.	Second hammer	1728		See fig. 13	
3.18.	Turn movement over				

4.0. DAY - DATE

4.1.	Day indicator guard	1555	By pressure	Extraction as per fig. 16
4.2.	Day indicator	1516		
4.3.	Date indicator guard	1554	3 screws 2673	
4.4.	Hour wheel	1231		
4.5.	Date and day jumper spring	1529		
4.6.	Date indicator	1580		
4.7.	Date and day jumper	1503		
4.8.	Double date setting wheel	1559		
4.9.	Intermediate wheel for hour recorder	1737		

Op. No.	Order of operations	Part No.	Fixing device	Remarks
4.10.	Hour wheel spring	1268		
4.11.	Date mechanism support	1527	4 screws 2674	Filmogeneous treatment excluded
4.12.	Date driving wheel	1564		Disassembling not necessary
	Date and day driver	1511		
4.12.	if disassembling : Date driving wheel post	5133		Remove from below
4.13.	Setting wheel	1113		
4.14.	Setting wheel spring	1169		Disassembling not necessary
	Date and day corrector	1530		
4.15.	if disassembling : Setting wheel for date and day corrector	7528		Remove from corrector side

5.0. LOWER CHRONOGRAPH MECHANISM



5.1.	24-hour wheel	1262		
5.2.	Hour recorder runner	1788		
5.3.	Minute heart, mounted	1760		
5.4.	Operating lever for hammers	1784		
5.5.	Hour and minute hammer	1783		
5.6.	Pillar wheel jumper	1727	1 screw 2583	
5.7.	Operating lever	1720		
5.8.	Operating lever hook	1718		
5.9.	Spring for operating lever hook	1719		
5.10.	Minute recorder bridge	1763	1 screw 2583	

6.0. HAND SETTING MECHANISM

6.1.	Minute wheel	1246		* Disassemble only if changing a faulty part
6.2.	Cannon pinion, mounted	1218		
6.3.	Setting lever spring	1110	1 screw 2583	
6.4.	Yoke spring	1112		
6.5.	Yoke	1111		
6.6.	Setting lever	1109		
6.7.	Winding stem	1106		
6.8.	Winding pinion	1108		
6.9.	Clutch wheel	1107		
6.10.	Unscrew stem cock	* 1040	3 screws 2689	
6.11.	Turn movement over			
6.12.	Spring-click	* 1104		

Op. No.	Order of operations	Part No.	Fixing device	Remarks
6.13.	Stem cock *	1040		* Disassemble only if changing a faulty part
6.14.	Stop-lever *	1123		
6.15.	Rotor support *	1046	by pressure	
6.16.	Hammer cam	1785		Disassembling not necessary
	Pillar wheel	1715		
6.16.	if disassembling : Pillar wheel post	5139	driven-in	Remove from bridges side
6.17.	Friction-spring for chronograph runner *	1735	driven-in	Direction as per fig. 15









7.0. CLEANING : *Clean all parts as per usual procedures, except for :*

7.1.	Barrel drum with spring			-Use pegwood for pivoting hole -If replacing spring 1208, lubricate drum wall with 
7.2.	Date indicator	1580		-Wipe teeth ; do not immerse in baths
7.3.	<u>Important</u>	-Do not use liquids based on trichlorethylene for parts in synthetic material. Filmogeneous treatments excluded. -Use preferably FREON ; are also suitable : benzine and methylated spirit. -The deposit left in the holes by the molykote  must not be removed.		

8.0. PRE-ASSEMBLING CONTROL

Op. No.	Part	Part No.	Check points
8.1.	Pillar wheel	1715	Freedom : end-shake 0.02 mm
8.2.	Stop-lever	1123	Freedom
8.3.	Friction-spring for chronograph runner	1735	Tension - see fig. 15
8.4.	Date driving wheel	1564	Freedom
8.5.	Date and day corrector	1530	Freedom
8.6.	Impulse click	1412	Position - see fig. 5

TABLE OF LUBRICANTS





	= Fine oil	= Synt-A-Lube 9010 or 1.02
	= Oil for heavy duty	= Microgliss D/5 or 1.14
	= Grease for pallets	= Grease F or 2.00
	= Grease	= Moebius 8200 or 2.01
	= Grease for heavy duty	= Moebius 8200 + 30% Molykote or 2.06
	= Silicone grease	= MS 4 or 2.04
	= Braking grease	= Blasolube 316 or 2.09
	= Greasing under the part	

ASSEMBLING

Op. No.	Order of operations	Part No.	Fixing device	Lubrication point	code	Remarks
---------	---------------------	----------	---------------	-------------------	------	---------

9.0. HAND SETTING MECHANISM

Fig. 2
(blown up)

9.1.	Winding pinion	1108				
9.2.	Clutch wheel	1107				
9.3.	Winding stem	1106	Pressure lever	All diameters		
9.4.	Setting lever	1109		stud		
9.5.	Yoke	1111				
9.6.	Yoke spring	1112				
9.7.	Setting lever spring	1110	1 screw 2583			
9.8.	Cannon pinion	1218		Pivot, under Wheel fitting	 	
9.9.	Minute wheel	1246		Post		
9.10.	Minute recorder bridge	1763	1 screw 2583			
9.11.	Oil the mechanism			as per fig.3		

10.0. WHEEL TRAIN - MOTOR AND UPPER CHRONOGRAPH MECHANISM

Fig. 1
(blown up)

10.1.	Second hammer	1728		as per fig.13		
10.2.	Chronograph runner	1705		as per fig.12		
10.3.	Fourth wheel	1243				
10.4.	Intermediate wheel	1212				
10.5.	Coupling gear	1712		as per fig.14		
10.6.	Coupling lever	1724		as per fig.10		

Op. No.	Order of operations	Part No.	Fixing device	Lubrication point	code	Remarks
10.7.	Crown wheel	1101		Post Tothing		
10.8.	Crown wheel cover	1168				
10.9.	Driving gear for ratchet wheel	1437		Plate pivot		
10.10.	Escape wheel	1305				
10.11.	3/4 plate bridge	1002	2 screws 2583			
10.12.	Coupling lever spring	1731	1 screw 2583			
10.13.	Ratchet wheel	1100		as per fig.9		
10.14.	Assembling : - barrel drum - ratchet wheel	1202 1100		hole		see fig. 19
10.15.	Oil barrel support			on plate		see fig. 19
10.16.	Barrel and ratchet wheel					
10.17.	Barrel axle	1204				see fig. 19
10.18.	Oil intermediate wheel	1212		under		
10.19.	Oil coupling gear	1712		under		
10.20.	Oil escape wheel	1305		under		

Fig. 3
(blown up)
The plate para-
shock device
must be assembled





11.0. CHRONOGRAPH MECHANISM - DIAL SIDE

11.1.	Operating lever	1720		3 points under		as per fig. 20
11.2.	Operating lever hook	1718				
11.3.	Spring for operating lever hook	1719				
11.4.	Pillar wheel jumper	1727	1 screw 2583			
11.5.	Oil minute recorder bridge	1763		Function with hammer		as per fig. 20
11.6.	Hour and minute hammer	1783		1 point under		as per fig. 20
11.7.	Operating lever for hammers	1784		1 point under		as per fig. 20
11.8.	Oil the functions			as per fig.20		
11.9.	Oil cannon pinion	1218		Pivot upper		
11.10.	Minute heart	1760		as per fig.2		
11.11.	Hour recorder runner	1788		as per fig.4		
11.12.	24-hour wheel	1262				
11.13.	Oil setting wheel for date and day corrector	7528		as per fig.7		
11.14.	Date mechanism support	1527	4 screws 2674			

Op. No.	Order of operations	Part No.	Fixing device	Lubrication point	code	Remarks
11.15.	Intermediate wheel for hour recorder	1737				





12.0. DAY - DATE

Fig. 4
(blown up)

12.1.	Oil post of double date setting wheel			on plate		
12.2.	Double date setting wheel	1559				
12.3.	Date and day jumper	1503		as per fig. 11		
12.4.	Date indicator	1580		as per fig.1		
12.5.	Hour wheel spring	1268				as per fig. 2
12.6.	Oil minute heart	1760		Hour wheel fitting		
12.7.	Hour wheel	1231				
12.8.	Date indicator guard	1554	3 screws 2673			Check that teeth of hour wheel and double date setting wheel engage correctly.
12.9.	Date and day jumper spring	1529				Located as per fig. 21
12.10.	Day indicator	1516				
12.11.	Day indicator guard	1555				see fig. 16
12.12.	Oil day indicator	1516		Pivoting		
12.13.	Oil hour wheel	1231		Pivoting		

13.0. ESCAPEMENT - ADJUSTMENT

Fig. 1
(blown up)

13.1.	Pallet fork	1316				
13.2.	Pallet cock	1005	2 screws 2583			
13.3.	Oil pallet fork	1316		Pallets		
13.4.	Oil shock-absorbing device for balance at plate	1346				
13.5.	Regulator	1334				see fig. 17
13.6.	Regulator driver	1357				
13.7.	Stud holder	1363				
13.8.	Oil shock-absorbing device for balance at balance cock	1347				
13.9.	Balance cock	1030	1 screw 2583			
13.10.	Oil intermediate wheel	1212		upper		
13.11.	Oil coupling gear	1712		upper		

Op. No.	Order of operations	Part No.	Fixing device	Lubrication point	code	Remarks
13.12.	Oil fourth wheel	1243		upper		
13.13.	Oil escape wheel	1305		upper		
13.14.	Oil driving gear for ratchet wheel	1437		upper		
13.15.	Oil coupling lever	1724		upper		
13.16.	Oil spring of coupling lever	1731		Function		

14.0. AUTOMATIC DEVICE

Fig. 1
(blown up)

14.1.	Stop click	1414				
14.2.	Reduction gear	1432		Pivot under		
14.3.	Automatic device bridge	1031	1 screw 2673			Warning : screw 2673 not 2583
14.4.	Oil reduction gear	1432		Teeth of wheel + pivot upper		
14.5.	Oil the rotor	1026		Pivoting of pinion 1429		
14.6.	Rotor pinion (on rotor)	1429				
14.7.	Oil rotor axle	1400		Rotor fitting + gib		
14.8.	Rotor, assembled	1026				
14.9.	Rotor gib	1451				
14.10.	Oil rotor pinion	1429		Toothing		

15.0. HAND FITTING

15.1.	Dial : Fixing effected by pressing on 4 h and 10 h.
15.2.	Set chronograph in return-to-zero position.
15.3.	Hands <i>Note : When fitting the sweep second hand, support the chronograph runner by pressing the tip of the rotor axle.</i>

16.0. CHECKING OF THE FUNCTIONS

	In order to act upon the operating levers of the chronograph mechanism, a stem with a tip diameter of 2.0 to 2.50 mm should be used.
16.1.	Effect a few start and stop operations and ascertain that the sweep second hand is reacting normally.
16.2.	After having started the chronograph and effected the stop, displace the 3 chronograph hands in various positions by means of a pegwood and check that resetting-to-zero of these hands functions correctly.

16.3.	Set the chronograph running and allow a few hours to elapse in order to ascertain synchronization of the hands.
16.4.	Check the changing of the date and day by moving the hands with the stem drawn to outer extreme, and then by means of the rapid corrector after having placed the stem in middle position.
16.5.	<u>Warning</u> : Correction of the day cannot be effected between 20 h 30' and 0 h 30' .
16.6.	In order to avoid damaging of the automatic winding mechanism, winding of the mainspring must be effected manually by means of the winding crown.

17.0. CASING-UP

17.1.	Before inserting the movement in the case, ascertain that the pushers function correctly.
17.2.	If necessary, disassemble them, oil the gaskets and reassemble, tightening the screws very thoroughly.
17.3.	Check condition of gaskets for the crown and case-back and lubricate.
17.4.	Lubricate the gaskets with Fömblin UT 18 or 2.07 ; see fig. 18 

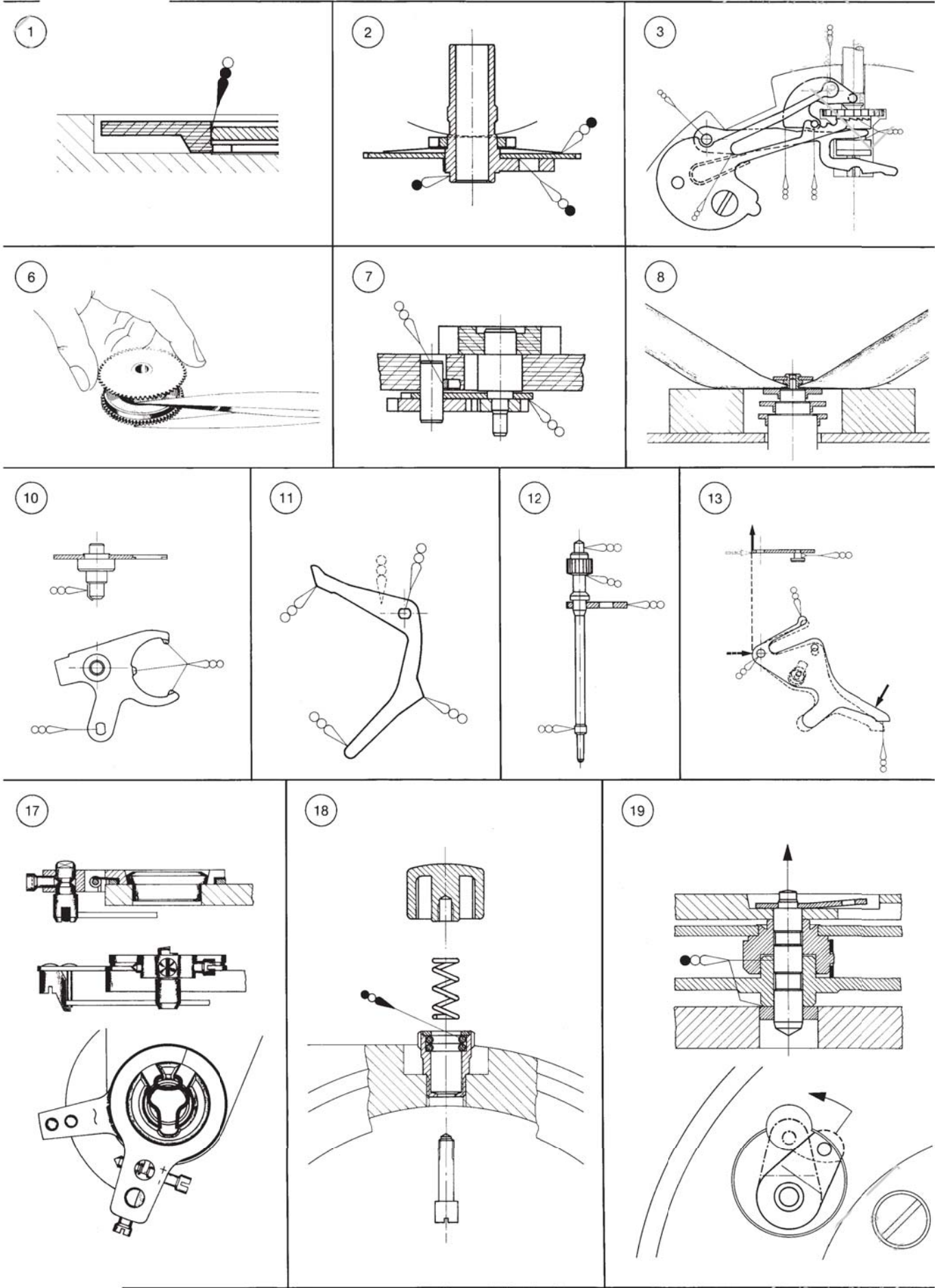

4

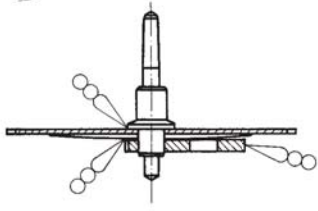

5

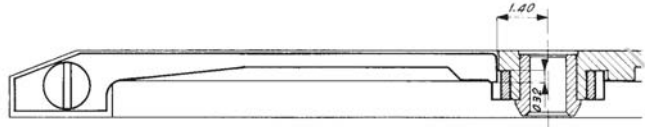

9

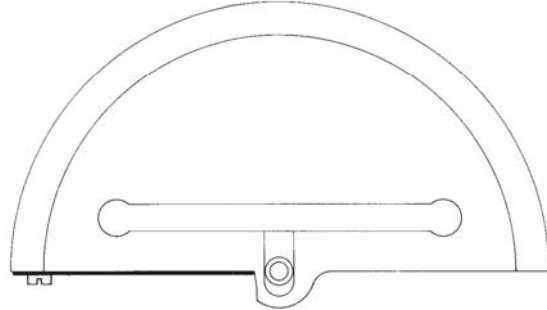
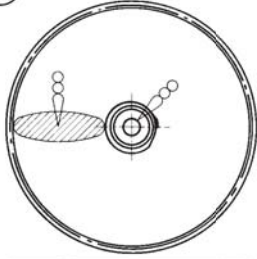

15

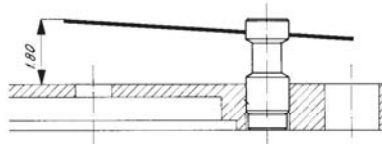

16

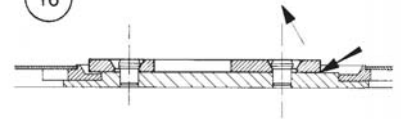

14

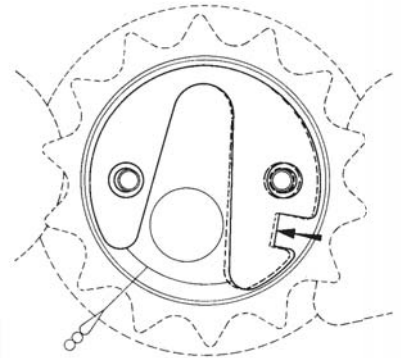
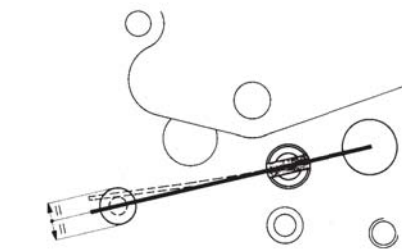
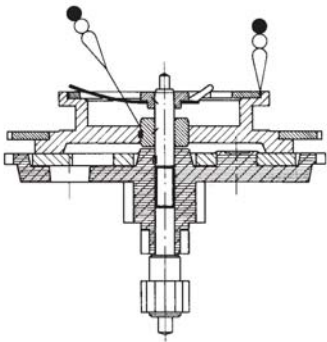

20

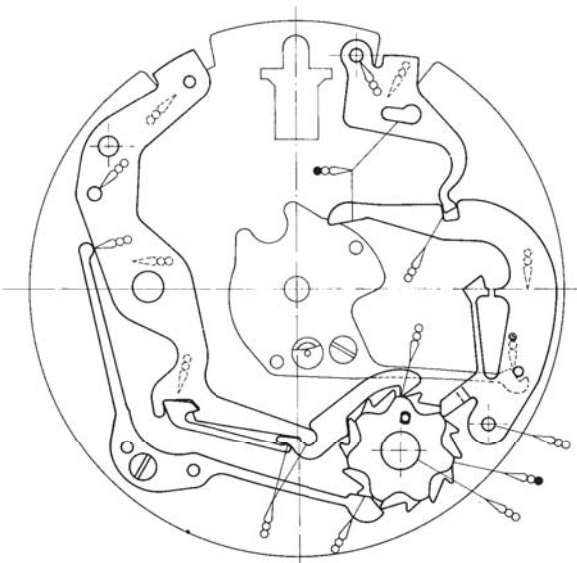

21

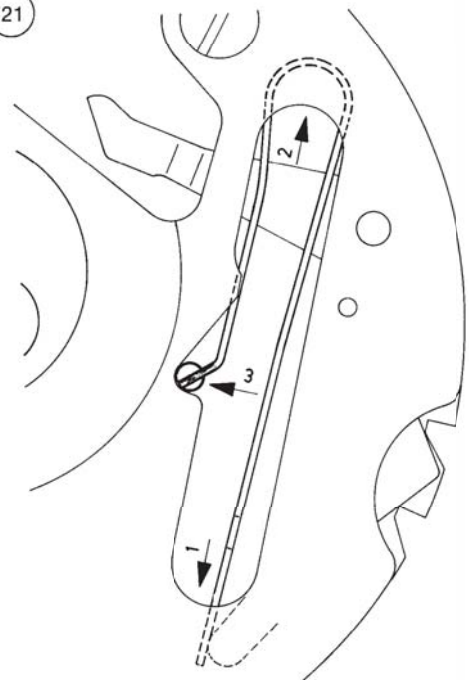

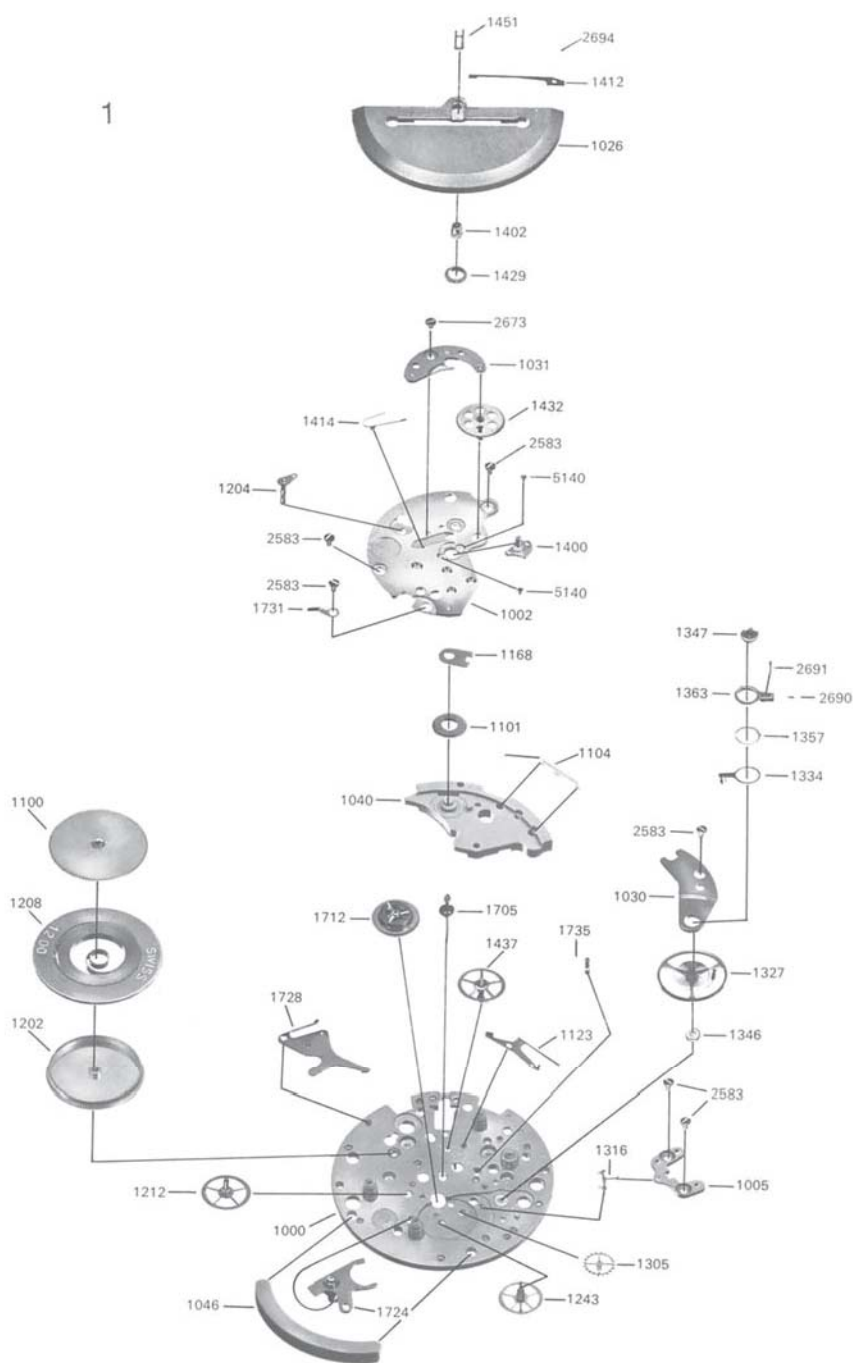

1000 Plate
 1002 3/4 plate bridge
 1005 Pallet cock
 1026 Rotor
 1030 Balance cock
 1031 Bridge for automatic device
 1040 Stem cock
 1046 Rotor support
 1100 Ratchet wheel
 1101 Crown wheel
 1104 Clicking spring
 1123 Stop-lever
 1168 Crown wheel lid
 1202 Barrel drum

1204 Barrel axle
 1208 Mainspring
 1212 Intermediate wheel
 1243 Fourth wheel
 1305 Escape wheel
 1316 Pallet fork
 1327 Balance complete
 1334 Regulator
 1346 Shock-absorbing device for balance, lower
 1357 Regulator driver

1363 Stud holder
 1400 Rotor axle
 1402 Rotor bearing
 1412 Impulse click
 1414 Stop click
 1429 Rotor pinion
 1432 Reduction gear
 1437 Driving gear for ratchet wheel
 1451 Gib of rotor
 1705 Chronograph runner
 1712 Coupling runner
 1724 Coupling yoke
 1728 Second hammer

1731 Coupling yoke spring
 1735 Friction spring for chronograph runner
 2583 Screw for 3/4 plate bridge
 2583 Screw for pallet cock
 2583 Screw for balance cock
 2673 Screw for bridge for automatic device
 2690 Screw for stud
 2691 Screw for regulator adjustment
 2694 Screw for impulse click
 5140 Rivet for rotor axle

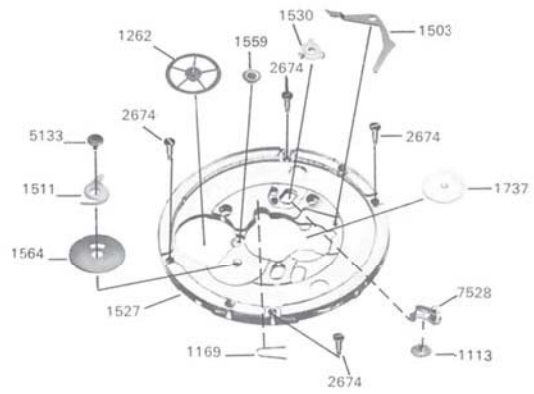
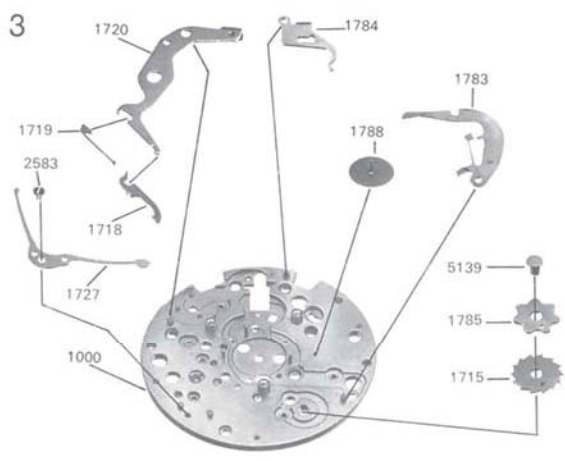
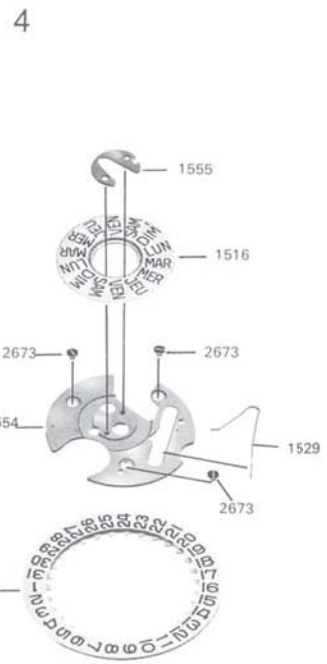
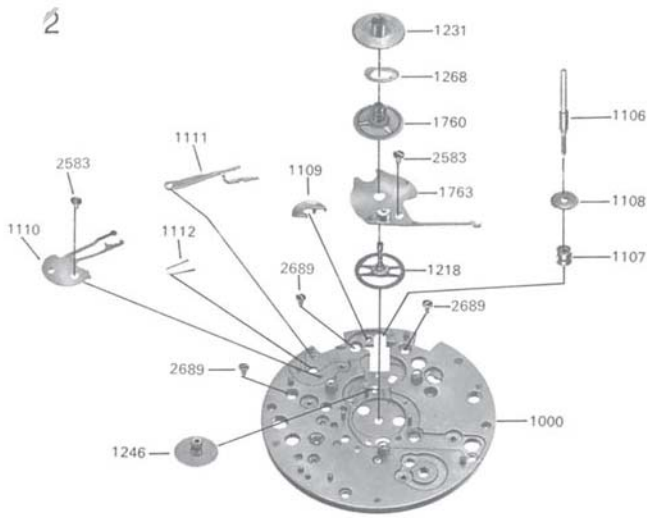

- 1000 Plate
- 1106 Winding stem
- 1107 Clutch wheel
- 1108 Winding pinion
- 1109 Setting lever
- 1110 Setting lever spring
- 1111 Yoke
- 1112 Yoke spring
- 1113 Setting wheel
- 1169 Setting wheel spring
- 1218 Cannon pinion
- 1231 Hour wheel
- 1246 Minute wheel
- 1262 24 hours wheel
- 1268 Hour wheel spring
- 1503 Date and day jumper

- 1511 Date and day driver
- 1516 Date indicator
- 1527 Support for date indicator mechanism
- 1529 Date and day jumper spring
- 1530 Date and day corrector
- 1554 Date indicator guard
- 1555 Day indicator guard
- 1559 Double date setting wheel
- 1564 Date indicator driving wheel
- 1580 Date indicator

- 7528 Date and day setting wheel corrector
- 1715 Pillar wheel
- 1718 Operating lever hook
- 1719 Operating lever hook spring
- 1720 Operating lever
- 1727 Pillar wheel jumper
- 1737 Intermediate wheel for hour recorder
- 1760 Minute heart
- 1763 Minute recorder bridge
- 1783 Hour and minute hammer

- 1784 Operating lever for hammers
- 1785 Hammer cam
- 1788 Hour recording runner
- 2583 Screw for setting lever spring
- 2583 Screw for minute recorder bridge
- 2583 Screw for pillar wheel jumper
- 2673 Screw for date indicator guard
- 2674 Screw for support for date indicator mechanism
- 2689 Screw for stem cock
- 5133 Date indicator driving wheel stud
- 5139 Pillar wheel stud